

FOR FURTHER DESIGN ASSISTANCE
PLEASE CALL PERFECTION AT
1-800-238-7207
OR 407-671-6225

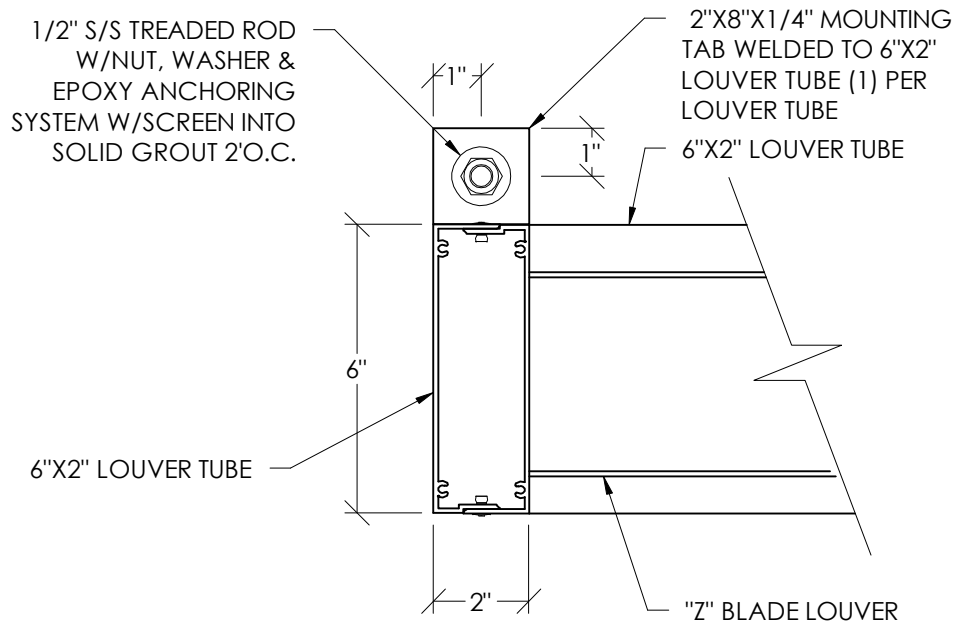

Perfection Architectural Systems, Inc

Service, Quality, Reliability.

2310 Mercator Drive, Orlando, FL 32807
407.671.6225 / 800.238.7207 Fax: 407.671.8252
www.perfectionarch.com

Sunshade Frame
Attachment Detail